

DIM.	TOL.
5mm DOWN	±0.2
5~20mm	±0.3
20~40mm	±0.4
40~60mm	±0.5
60~100mm	±0.8
100mm UP	±1.0

REVISIONS			
REV	DESCRIPTION	DATE	BY

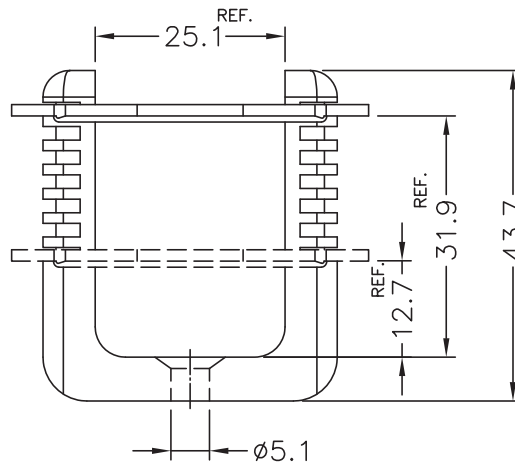
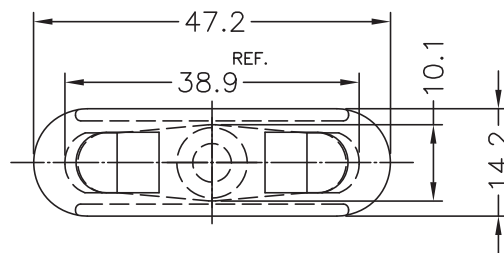
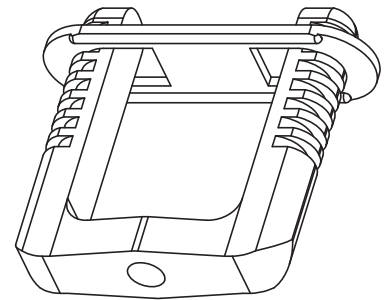

NOTE:

1. Shrinking is normal status.
2. All measurement does not include gate which raises under 0.3 mm.



				TITLE WIRE MOUNT		
				MATERIAL NYLON 66 UL94-V-2	DATE 15/09/2015	
				DRAWN S.P.		
PART NUMBER 10962AA00		DRAWING NUMBER 15.09.15.10962.0.E		COLOR NATURAL		CHECK
SIZE A4	SCALE 1:1	UNIT mm	REV A	UNLESS OTHERWISE SPECIFIED TOLERANCE SEE ABOVE		APPROVED