

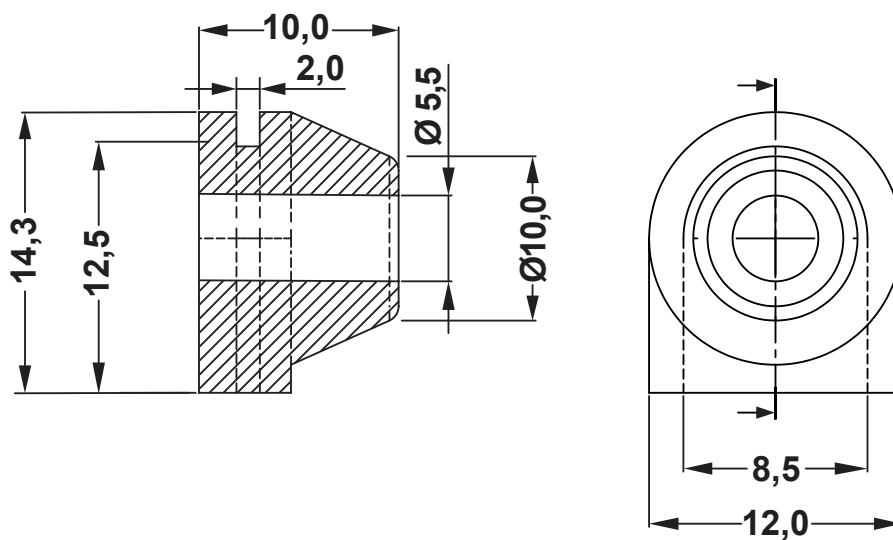

REVISIONS			
REV	DESCRIPTION	DATE	BY



				TITLE	EDGE GROMMET		
				MATERIAL	PVC	DATE	16/12/2013
PART NUMBER 10951CA01				FINISH		DRAWN	V.P.
				DRAWING NUMBER	13.08.07.10951.E.0	COLOR	BLACK
SIZE	A4	SCALE	NTS	UNIT	mm	REV	
				UNLESS OTHERWISE SPECIFIED TOLERANCE	DIN ISO 3302-1 M2	APPROVED	