

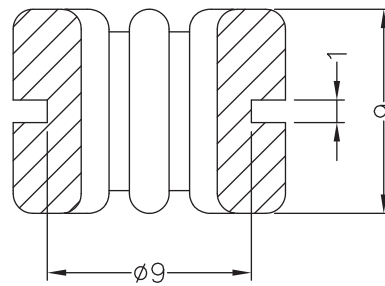

DIM.	TOL.
5mm DOWN	±0.2
5~20mm	±0.3
20~40mm	±0.4
40~60mm	±0.5
60~100mm	±0.8
100mm UP	±1.0

REVISIONS			
REV	DESCRIPTION	DATE	BY

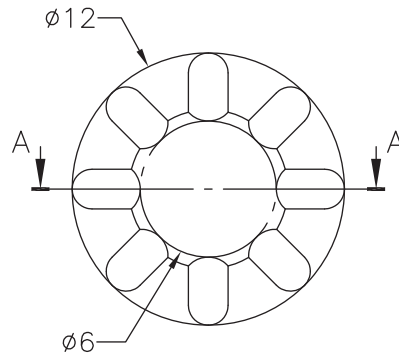

SECTION A-A



				TITLE ANTI-VIBRATE GROMMET			
				MATERIAL TPE		DATE 15/09/2015	
				HARDNESS 45°C ± 10°C		DRAWN S.P.	
PART NUMBER 10752PF01		DRAWING NUMBER 15.09.15.10752.0.E		COLOR BLACK		CHECK	
SIZE A4	SCALE 3:1	UNIT mm	REV A	UNLESS OTHERWISE SPECIFIED TOLERANCE SEE ABOVE		APPROVED	