

DIM.	TOL
5mm DOWN	±0.2
5~20mm	±0.3
20~40mm	±0.4
40~60mm	±0.5
60~100mm	±0.8
100mm UP	±1.0

REVISIONS			
REV	DESCRIPTION	DATE	BY

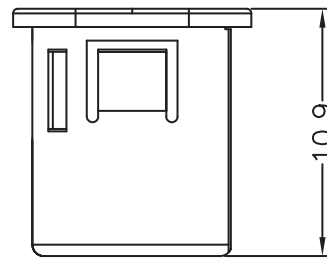
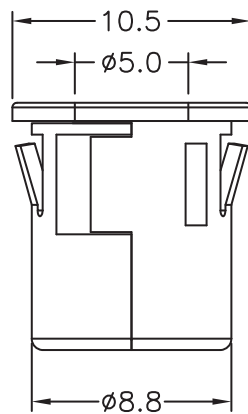
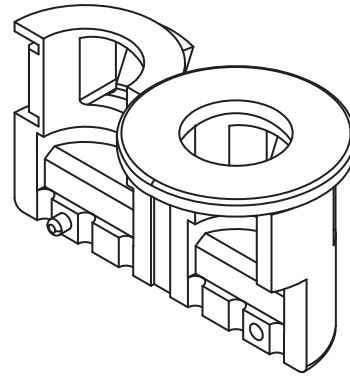
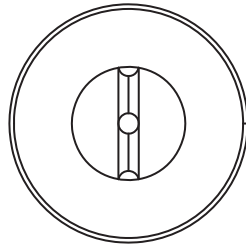

HOLE IN CHASSIS: $\phi 9.0^{+0.05}_{-0}$
 CHASSIS THICKNESS: 0.6~1.0

NOTE: 1. All measurement does not include gate which raises under 0.3mm.
 2. Suitable for $\phi 5$ LED with visor and 3PIN.



TITLE LED HOLDER	
MATERIAL PA66 V2 UL94	DATE 17/05/2011
COLOR BLACK	DRAWN J.D.
UNLESS OTHERWISE SPECIFIED TOLERANCE SEE ABOVE	CHECK APPROVED

PART NUMBER 10590AA01	DRAWING NUMBER 11.05.17.10590.0.E
SIZE A4	SCALE NTS
UNIT mm.	REV A