

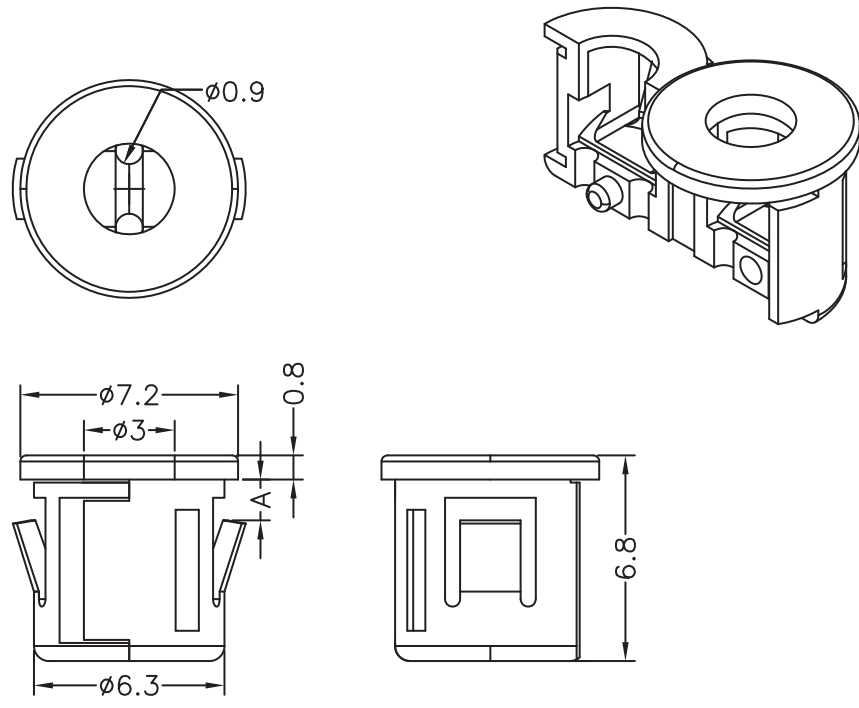

DIM.	TOL
5mm DOWN	±0.2
5~20mm	±0.3
20~40mm	±0.4
40~60mm	±0.5
60~100mm	±0.8
100mm UP	±1.0

REVISIONS			
REV	DESCRIPTION	DATE	BY



A: HOLE IN CHASSIS: $\phi 6.35 \sim \phi 6.4$
 CHASSIS THICKNESS: 1.0~1.2

NOTE: 1. All measurement does not include gate which raises under 0.3mm.
 2. Suitable for $\phi 3$ LED with visor and 2PIN.

				TITLE LED HOLDER	
				MATERIAL PA66 V2 UL94	DATE 17/05/2011
PART NUMBER 10589AA01				DRAWN J.D.	
				DRAWING NUMBER 11.05.17.10589.0.E	
SIZE A4				COLOR BLACK	
SCALE NTS				CHECK	
UNIT mm.				APPROVED	
REV A				UNLESS OTHERWISE SPECIFIED TOLERANCE SEE ABOVE	