

DIM.	TOL.
5mm DOWN	±0.2
5~20mm	±0.3
20~40mm	±0.4
40~60mm	±0.5
60~100mm	±0.8
100mm UP	±1.0

REVISIONS			
REV	DESCRIPTION	DATE	BY

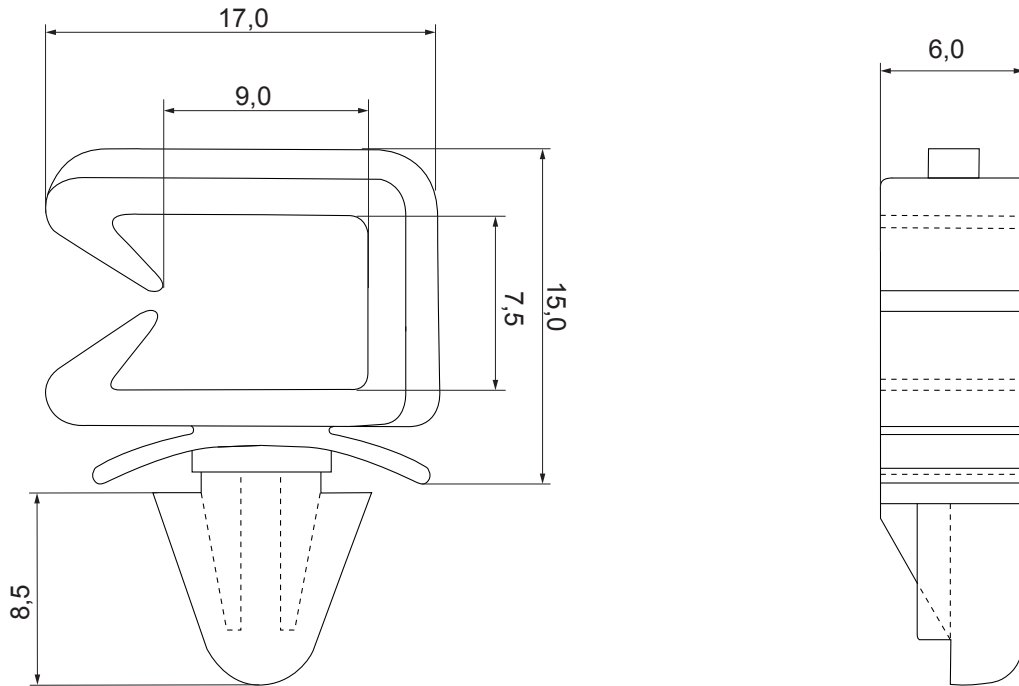

PANEL HOLE: Ø 6,5
THICKNESS: 0,5 - 1,5



				TITLE WIRE CLIP - SIDE OPENING	
				MATERIAL PA 66 V2 UL94	DATE 15/09/2015
				HARDNESS	DRAWN S.P.
PART NUMBER 0019AA01		DRAWING NUMBER 15.09.15.0019.0.E		COLOR BLACK	
SIZE A4	SCALE NTS	UNIT mm	REV A	UNLESS OTHERWISE SPECIFIED TOLERANCE SEE ABOVE	
				CHECK APPROVED	