

LICHTLEITER

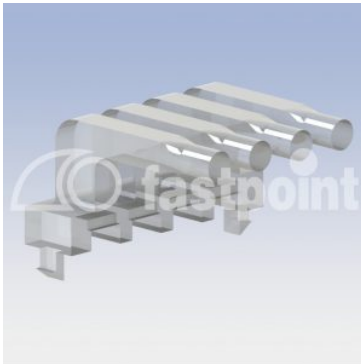

90° gebogener Lichtleiter zum Transport von Signallicht an die Frontplatte einer Applikation

Technische Beschreibung

Material: PC

Farbe: transparent

Entflammbarkeit: V2 (UL94)

Temperaturbereich: -40°C ~ +80°C

Alle Maße sind in mm

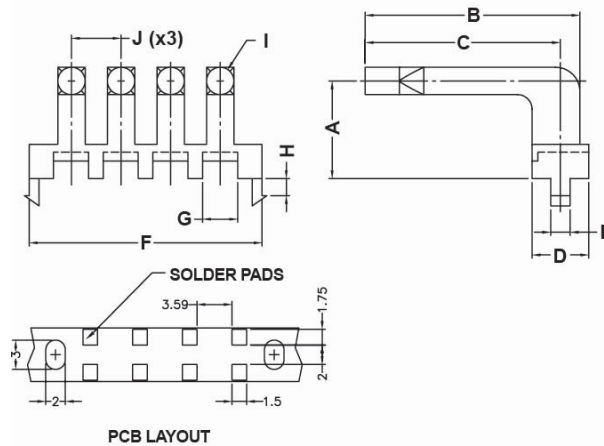

Produktvarianten

CODE	A	B	C	D	E	F	G	H	I	J	VPE-Stckz.
14078NA00	5,0	16,0	14,0	5,8	2,0	23,8	3,6	1,75	Ø 2,8	5,0	500
14079NA00	5,0	19,0	17,0	5,8	2,0	23,8	3,6	1,75	Ø 2,8	5,0	500
14080NA00	5,0	22,0	20,0	5,8	2,0	23,8	3,6	1,75	Ø 2,8	5,0	500
14081NA00	10,0	16,0	14,0	5,8	2,0	23,8	3,6	1,75	Ø 2,8	5,0	500
14082NA00	10,0	19,0	17,0	5,8	2,0	23,8	3,6	1,75	Ø 2,8	5,0	500

CODE	A	B	C	D	E	F	G	H	I	J	VPE-Stckz.
14083NA00	10,0	22,0	20,0	5,8	2,0	23,8	3,6	1,75	Ø 2,8	5,0	500
14084NA00	15,0	16,0	14,0	5,8	2,0	23,8	3,6	1,75	Ø 2,8	5,0	500
14085NA00	15,0	19,0	17,0	5,8	2,0	23,8	3,6	1,75	Ø 2,8	5,0	500
14086NA00	15,0	22,0	20,0	5,8	2,0	23,8	3,6	1,75	Ø 2,8	5,0	500